



SG servo

So Good Servo Technology Company





Index

01 | Company Overview

02 | Products

Business field

General hydraulic & pneumatic

Servo hydraulic

Electric driving

03 | Facilities

Production / Test / Inspection

04 | Certificates and Patents



Company Name	SG SERVO Co., Ltd.	CEO	Kim Go-do, Lee Hyeon-Cheol
Location	135, Charyongdanji-ro, Uichang-gu, Changwon-si, Gyeongsangnam-do, South Korea	Date of Foundation	January 19, 2002
		Employee	56
Size	Land : 3,089㎡ (33,250 ft ²) Floor space : 2,737㎡ (29,460 ft ²)	Total Sales(\$)	7.25 million
Business Areas	<input type="checkbox"/> Defense Application : Military Vehicle, Submarine, Unmanned Aerial Vehicle - Hydraulic Pumps, Hydraulic Servo and Proportional valves, Hydraulic Cylinders Decelerators, Manifold Assy', Hydraulic and Electric Actuator		
URL	Homepage : http://www.sgservo.co.kr		

2018

- Won Minister of National Defense prize
 - Obtained DQMS certification
- * DQMS(The Data Quality Management System)

2014

- Selected as Advanced Technology Center
- Obtained AS 9100 certification
- Obtained ISO 14001 certification

2010

- Won Korean Intellectual Property Office Director Prize
- Obtained TS 16949 certification

2005

- Obtained ISO 9001 certification
- Established **R&D center**

2002

- Established **SG SERVO** Co.,LTD

Defense



Civilian



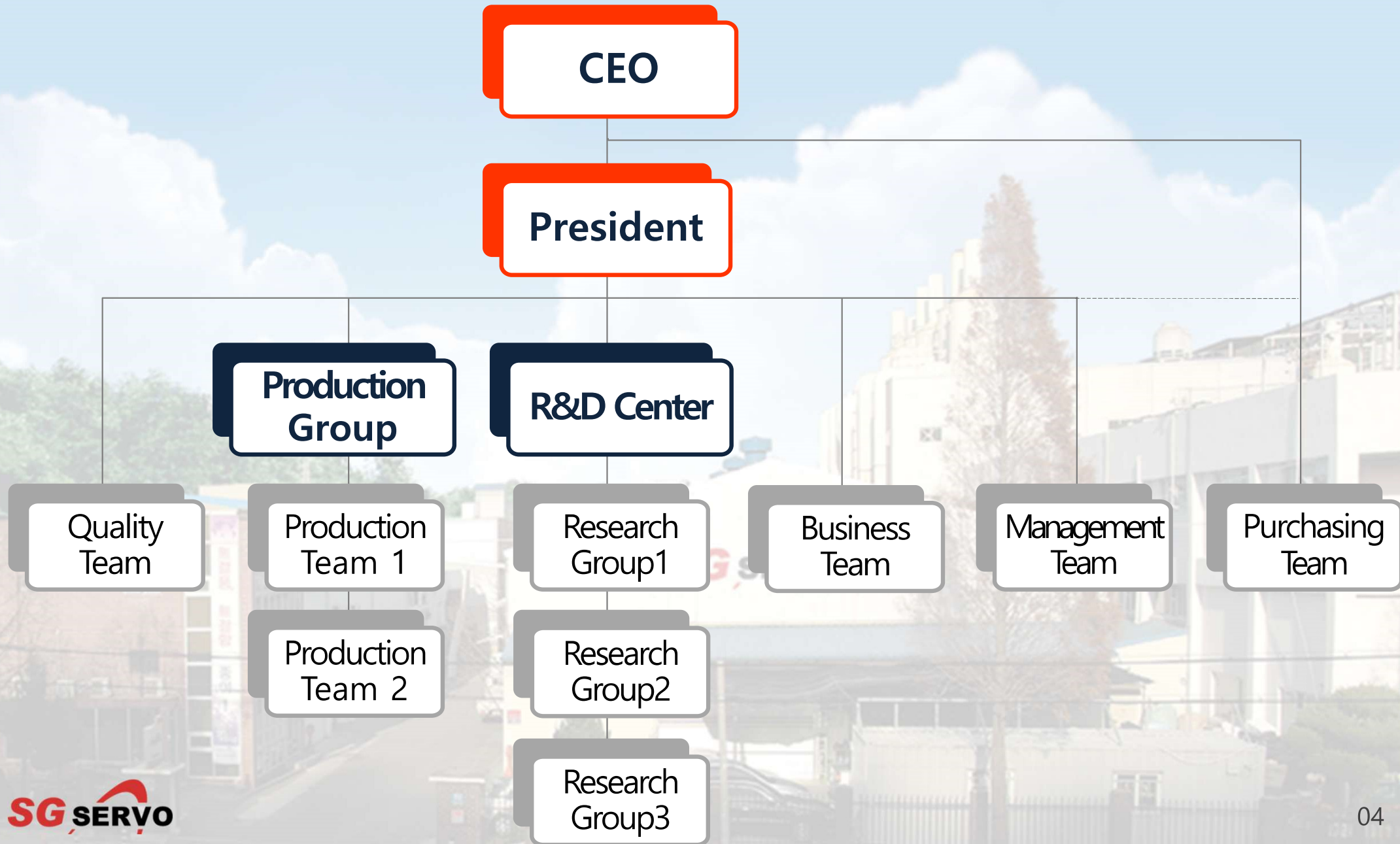

SG SERVO

SG

Short for 'SO GOOD', it exemplifies our will to make products with functions and quality that satisfy customers.

SERVO

SERVO shows our promise to serve customers and employees with spirit of **Servant** and our aim to become the world's best servo technology company.

Red Circle

Expresses the fluttering feeling of movement with the passion of youth, stirring the blood and a progressive spirit

Vision

The Company provides **Total Solutions** for motion control

Major Business

Drive control for
Ground Defense
equipment

Drive control for
Maritime & Aviation
equipment

Drive control for
civilian field

Key Capabilities

Servo Hydraulic
Technology

Electronic Driving
Technology

General
Hydraulic & Pneumatic
Technology

Management Policy

Conviction

- Thinks outside the box
- Responsibilities and Authorized Behavior

Challenge

- Develop new product line
- Entry into new markets

Communication

- Together Organizational Culture
- Communication and Consideration

- Hydraulic valve · Hydraulic pump
- Hydraulic cylinder · Hydraulic system

General hydraulic & pneumatic

**SG
Servo**

Electric driving

- Decelerator · Cylinder
- Electric-drive actuator

Servo hydraulic

- Servo valve · Servo actuator
- Proportional valve



Gear pump

- Application: Transmission of military trucks
- Feature & Function : Gerotor gear type, Mission oil circulation



Gear pump

- Application : Transmission of military vehicle
- Feature & Function : Internal / External gear type pump



Module valve assembly

- Application: Military vehicle, Industry hydraulic power pack
- Feature & Function : Sandwich type module Directional, Flow and pressure control valve



Manifold / wheel valve

- Application : Military vehicle
- Feature & Function : Central Tire Inflation System



Control valve

- Application: Transmissions of military vehicle
- Feature & Function : Hyd' power control by lever operation



Regulating valve

- Application: Transmissions of military vehicle
- Feature & Function: Built-in multi Spool valves, Pressure control in speed change



Steering valve

- Application: Transmissions of military vehicle
- Feature & Function : Built-in multi Spool valves, Track direction control



Relay valve

- Application: Transmissions of military vehicle
- Feature & Function : Built-in multi Spool valves, Hyd' power deliver to steering, Regulating & control valve

02

Products

General hydraulic & pneumatic

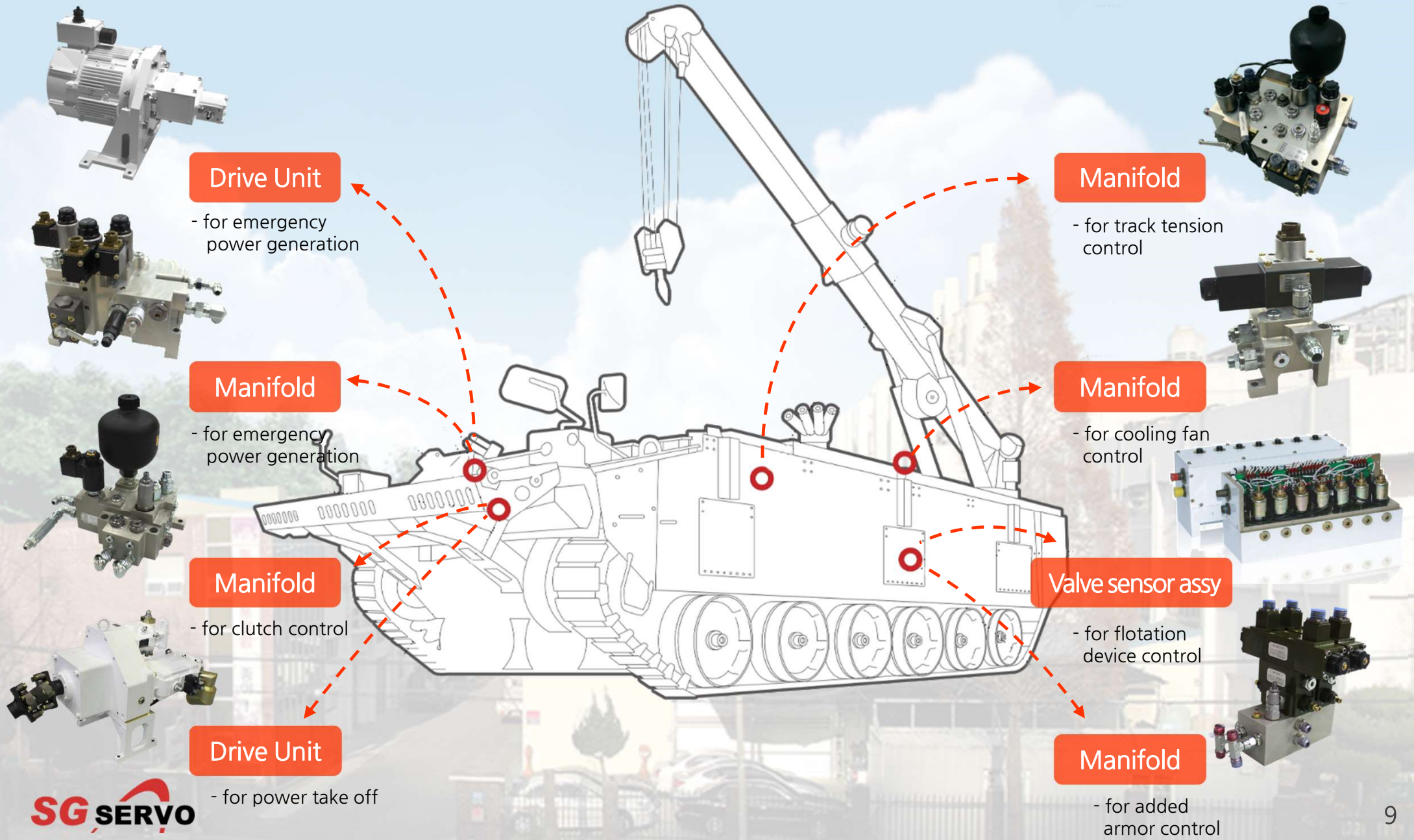



Quick coupling

- Application : Military vehicle
- Feature & Function : Quick coupling for hydraulic equipment



Hydraulic cylinder

- Application: Position control device of radar
- Feature & Function: Built-in pilot valves & Relief valve



Damper

- Application : Military vehicle(Bi-Ho)
- Feature & Function: Limit the elevation angle and damping



UAV Parts

- Application : UAV
- Feature & Function : Valve, filter, deicing fluid tank Etc.



Piston pump

- Application : Military vehicle
- Feature & Function : 350bar, 110cc/rev



Maglev trains

- Emergency Roller System : Move car bodies of maglev trains in an emergency
- Steering cylinder: Driving safety improved for Maglev trains
- Manifold: Steering cylinder control block for Maglev trains



SAD(Safety Arm Device)

- Application: Space launch vehicle
- Feature & Function: Safety arm device



DDVC

- Application: Hydraulic press /Tension/ Compression testers
- Feature & Function: Maximize energy efficiency united Pump, Motor & cylinder



Proportional valve

- Application: Ship gun
- Feature & Function: Spring balance type, Position control of ship gun



Pitch control valves

- Application: Propeller pitch control device of ship
- Feature & Function: Spool valve type, Mechanical servo, Propeller pitch control

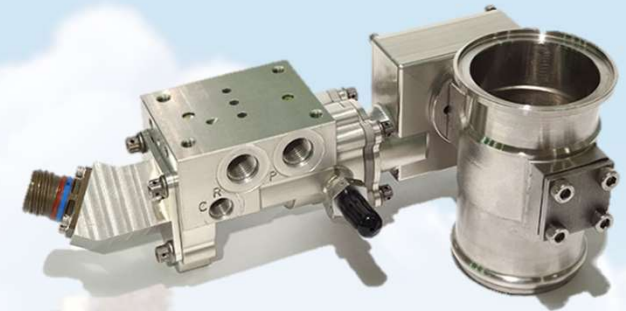

Servo actuator

- Application : Military Fighter



Servo valve's body

- Application : Military vehicle, Self propelled howitzer
- Feature & Function : Traverse/ elevation/ suspension control



Servo valve's Spool

- Application : Military vehicle, Self propelled howitzer
- Feature & Function : Traverse/ elevation/ suspension control



Servo valve's Sleeve

- Application : Military vehicle, Self propelled howitzer
- Feature & Function : Traverse/ elevation/ suspension control



Servo valves

- Feature & Function: 2 stage, Nozzle Flapper type servo valves

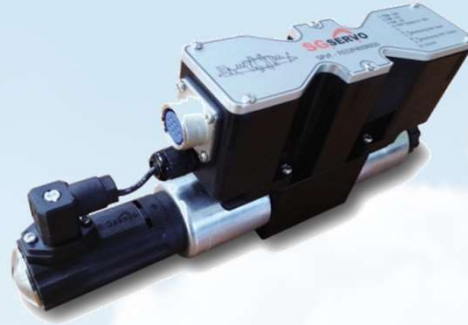

Proportional valves

- Application: Injection molding machine and press
- Feature & Function: Built in control amplifier, Injection material volume control



Servo actuator

- Application : Hydraulic press, etc
 - Feature & Function: Use overshoot prevention
- SG SERVO applied for patent



Spool & Sleeve

- Application: Rolling facilities
- Feature & Function: For controlling the gap of rolling/ roller



Resistance flow control valves

- Application: Diesel engines
- Feature & Function: Control flow of diesel vehicle common rails



Relief valves

- Application: Diesel engines
- Feature & Function: Control pressure of diesel vehicle common rails

Diesel engine

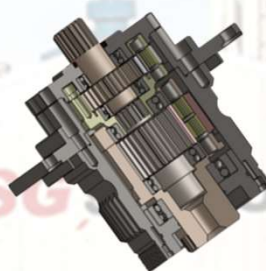
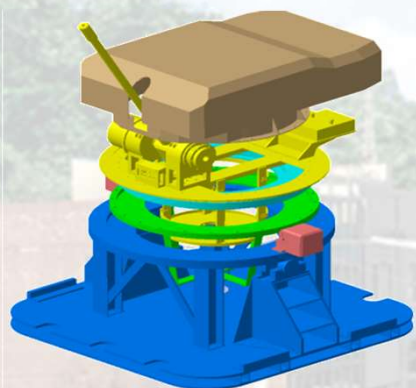
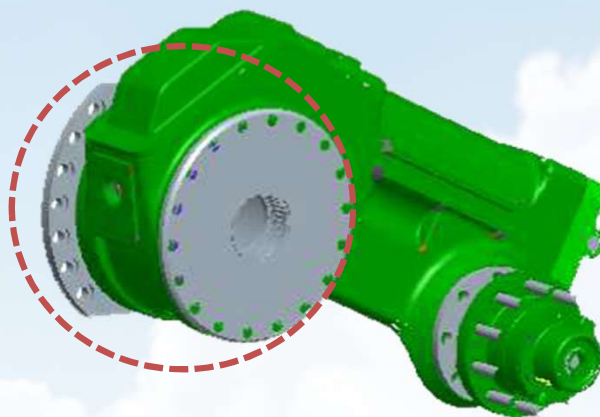
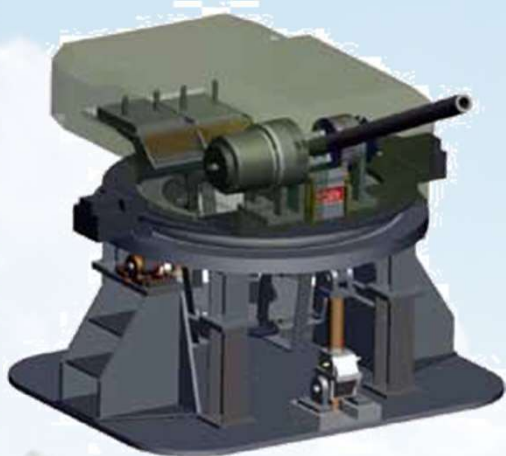

Turret Direct Drive System

- Application : Turret Direct Drive System test Facilities
- Feature & Function: Test facilities using electric power

Decelerator Ass'y

- Application : Active suspension (Hanwha defense)
- Decelerate ratio : 7.56:1
- Rated torque/backlash : 1,905N-m/24arcmin ↓

Auxiliary winch

- Application : Military vehicle(Doosan Mottrol)
- Decelerate ratio : 5.75:1
- Max.Output torque/Input speed: 1,300N-m/600rpm

Hoistable Mast

[Rader/Attack-Search for optronic head/Snorkel Mast]
 · Feature & Function : Electric Drive System
 Max.Output 5kW, Max.Speed 300mm/sec
 Stroke 2,400~3,600mm

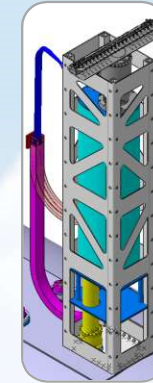

Radar

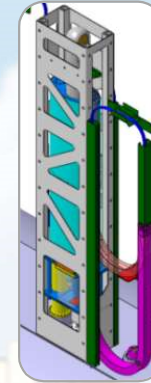

Attack / Search
Optronic Head

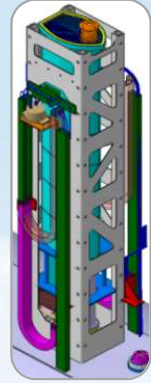
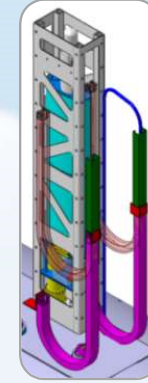

Snorkel

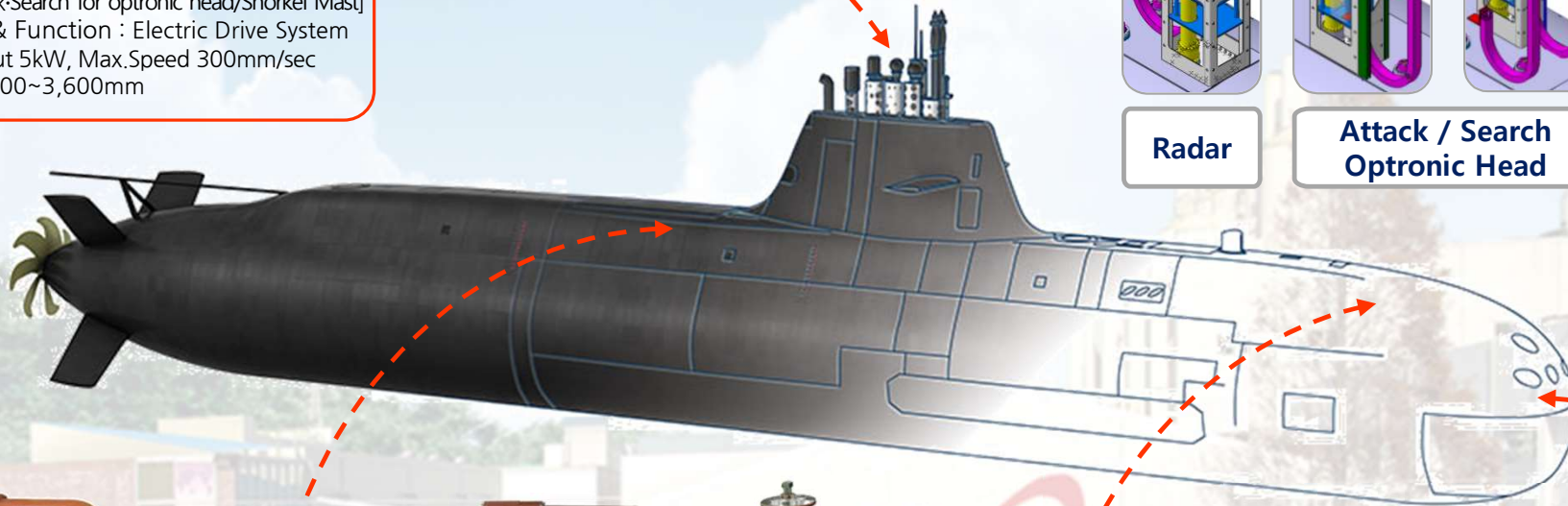

Electric Actuator

· Electric Drive System , Self-tuning control
 · Feature & Function : Max. Thrust 2,000kgf,
 Rated speed 7.5mm/sec, Stroke 335mm

Electric Actuator

[All Actuator] - Electric Drive System
 · Feature & Function : Max. Thrust 1,000kgf,
 Rated speed 16mm/sec, Stroke 245mm
 [Top stop Actuator] - Electric Drive System
 · Feature & Function : Max. Thrust 1,500kgf,
 Rated speed 16mm/sec, Stroke 20mm

Manual Actuator

· Manual drive System
 · Feature & Function : Max. lateral load 3,500kgf,
 Stroke 410mm

Flood & Drain Ball Valve
(add Hydraulic Actuator)



Hull Ball Valve



Globe Valve



Year	Product	Remark
2002	Ball Valve 28Sets(40A ~ 200A)	Park Wi-ham
2003	Ball Valve 53Sets (32A ~ 200A) Flap Valve 46Sets (50A ~ 125A)	Choi Wireless
2004	Ball Valve 53Sets (32A ~ 200A)	Jeong Woonham
2006	Ball Valve 53Sets (32A ~ 200A) Flap Valve 46Sets (50A ~ 125A)	Yi Sun-Shin
2016~2020	Ball Valve 390Sets (32A ~ 200A) Flap Valve 130Sets (50A ~ 250A)	Class 214 (Work Son Won, Stopped, Jung Geun Ahn)
2017	DIN Valve Sounding Ball Cock, Auto Vent Valve Sight Glass valve, Globe valve, globe check valve angle valve, angle check valve, ball valve	Hyundai Heavy Industries Special Ship Division 500-ton class P141/P142
2020	Delivered 18 kinds of submarine valves to Taiwan	



V-MCT



H-MCT

No.	Facility name	Model / Maker	EA
1	H-MCT	KH-63G / WIA, Etc.	4
2	V-MCT	VX500,50 / WIA, Etc.	4
3	CNC	PUMA-280 / Doosaninfracore, Etc.	5
4	Universal milling Machine	TK-VS5N / TAKEDA	1
5	Honing machine	CVH-03S / Cleantec, Etc.	2
6	Wrapping machine	KE-610 / Ibche corporation, Etc.	2
7	Vertical boring turning lathe	OKUMA 3VR / OKUMA	1
8	Air compressor	GSS11 / Airplus, Etc.	4
9	Ultrasonic washer	UIL-40040H / UIL Ultrasonic	1
10	Laser marking machine	F9020 / MACSA	1



Servo valve Test equipment



Pump Test equipment

No.	Facility name	Spec. / Maker	EA
1	Valve Test equipment	315bar, 130 l/min / Perfect	1
2	Valve Test equipment	210bar, 12Lpm / Perfect	1
3	Valve Test equipment	5000psi, 80Lpm / Perfect	1
4	Servo valve Test equipment	350bar, 120Lpm / STI	1
5	Pump/Valve Test equipment	3~200kg/cm ² , 10~400Lpm 4600rpm / Perfect	1
6	PUMP Test equipment	Max.400bar, Max.250Lpm / STI	1
7	PUMP Test equipment	450LT, 2450rpm / Perfect	1
8	Decelerator Test equipment	1300N/m, 600rpm / Estech	1
9	PTO Test equipment	1180rpm, 360rpm / Perfect	1
10	Sensor Test equipment	0~0.4Mpa / Perfect	1



HSU valve Test equipment

No.	Facility name	Spec. / Maker	EA
11	Freewheel Test equipment	1.1kg/cm ² , 180~300rpm / SG SERVO	1
12	Quick Coupling Test equipment	70bar, 70Lpm 15bar, 800Lpm / Perfect	1
13	* HSU valve Test equipment	210bar, 60Lpm 50bar, 100Lpm 700bar, 111Lpm / Perfect	1
14	Manifold / wheel valve Test equipment	10kg/cm ² / COMO	1
15	Constant climatic testing chambers	-50℃~150℃, 30~98%RH / NewZone Tech, Etc.	2

* Hydrostatic Steering Unit



3D measuring machine



Roundness measuring machine

No.	Facility name	Spec. / Maker	EA
1	3D measuring machine	500x600x400 / ZEISS	1
2	2D measuring machine	Vertical 3, 0~600mm / TRIMOS	2
3	Surface Tester	CD 120 / Mahr	1
4	Fluid Control Unit	FCU2110-4 V3.31 / HYDAC	1
5	Illuminometer	SJ301 / MITUTOYO	1
6	Hardness meter	DTR-200N, 150kg / Daekyung tech, Etc.	2
7	Roundness measuring machine	0.01 μm / kosaka	1
8	Micro Meter	0~25 / MITUTOYO	29
9	Gage	0~600 / MITUTOYO, Etc.	133
10	Vernier Caliper	0~300, 0~1000 / MITUTOYO	7
11	Tension and compression tester	SY10800-50 / SHIN YOUNG	1

ISO9001

AS9100

ISO14001

DQMS*

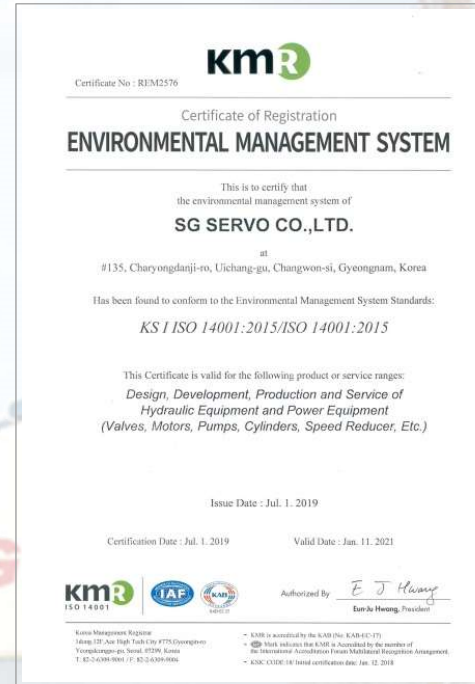
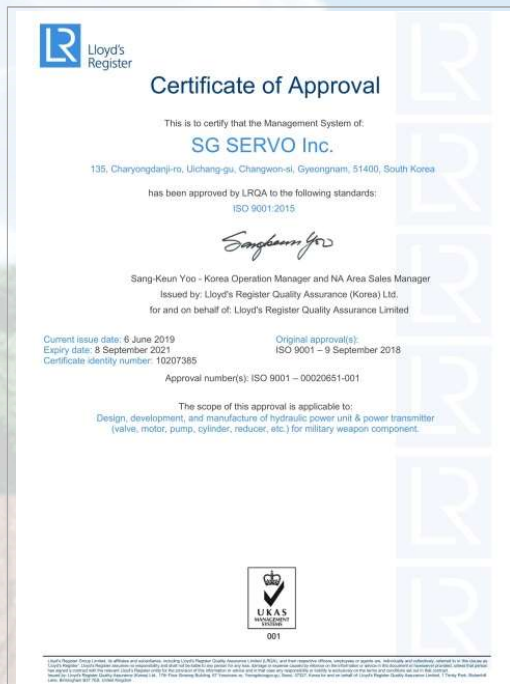

*DQMS(The Data Quality Management System)

Hydraulic Rotary Actuator Hydraulic Rotary Actuator

Piston Pump

Piston Pump



Quick Coupling



Breakaway Coupling



Conveyor Ball Bearings

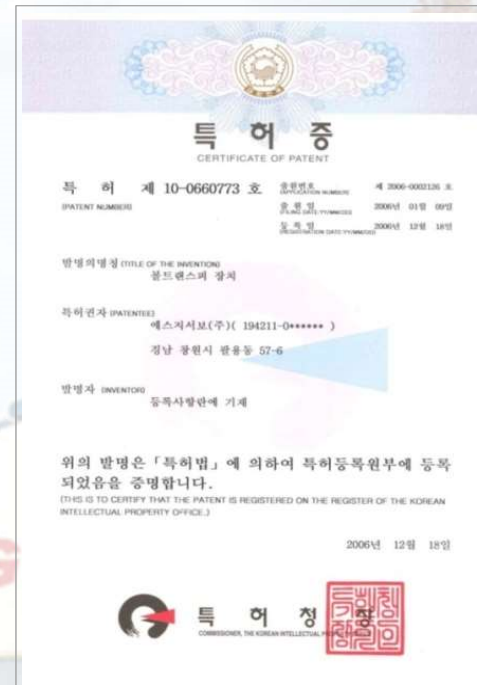

Servo Actuator

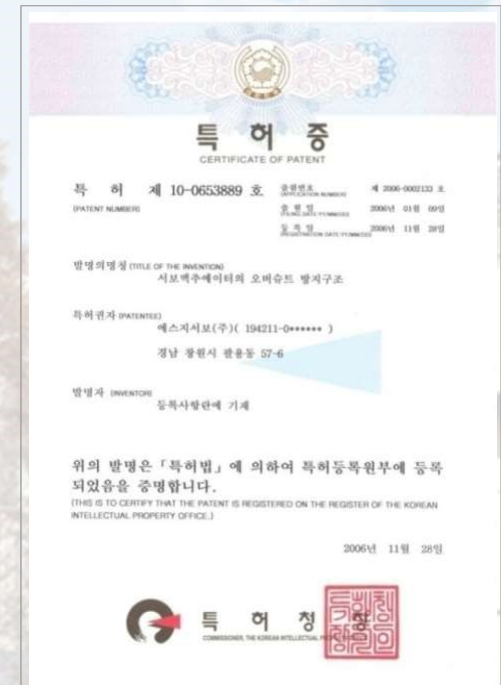



“Innovation of Motion Control, **SG SERVO**”



- Address : 135, Charyongdanji-ro, Uichang-gu, Changwon-si, Gyeongsangnam-do, South Korea 51400
- Tel. : 82-55-296-1873, 4
- Fax : 82-55-296-1875
- Homepage : <http://www.sgservo.co.kr>
- E-mail : buiz@sgservo.co.kr



Thank you